

Rev No.	Description of Revision	Date	Name	Approved	ECN No.
△					

NOTES:
 1.MATERIAL:
 MOLDING: LCP UL94 V-0
 CONTACT:COPPER ALLOY.
 GOLD PLATED Min ON CONTACT AREA,100u”
 Min TIN (LEAD FREE) ON SOLDER AREA,
 SHELL: SUS201-H,T=0.30±0.03mm
 50u” NICKEL PLATING OVER ALL.

2.MECHANICAL:
 INSERTION: 5~20N.
 EXTRACTION: 8~20N AFTER TEST.
 DURABILITY: 5000 CYCLES

3.ELECTRICAL:
 CURRENT: 3A FOR VBUS;
 1.25A FOR GND PIN.
 0.25A FOR OTHER.
 VOLTAGE: 20 V MAX
 WITHSTANDING VOLTAGE: 100V AC R.M.S.
 CONTACT RESISTANCE: 40mΩ MAX.
 INSULATION RESISTANCE: 100MΩ MIN.

4.ENVIRONMENTAL
 TEMPERATURE RANGE -25°C ~ +85°C

5. 尺寸标注事项:
 图示有标示“△”者为首样全检,重点管控尺寸.

6. 产品符合RoHS标准.

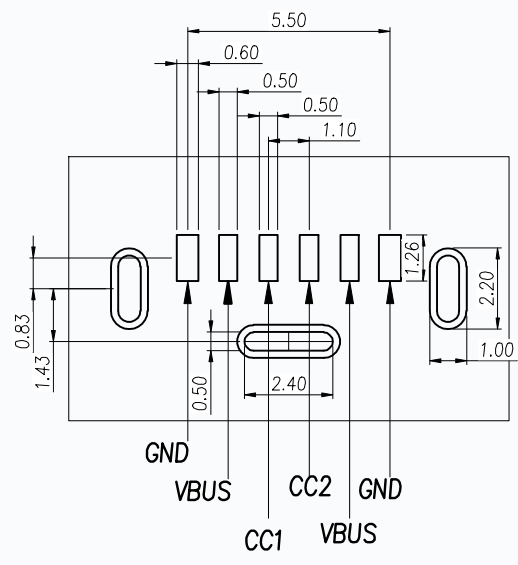
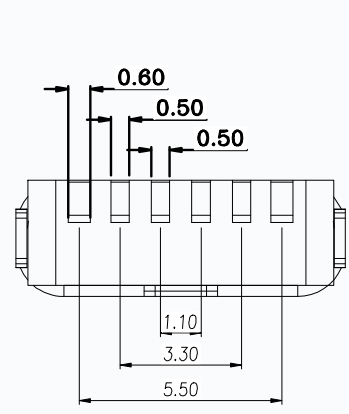
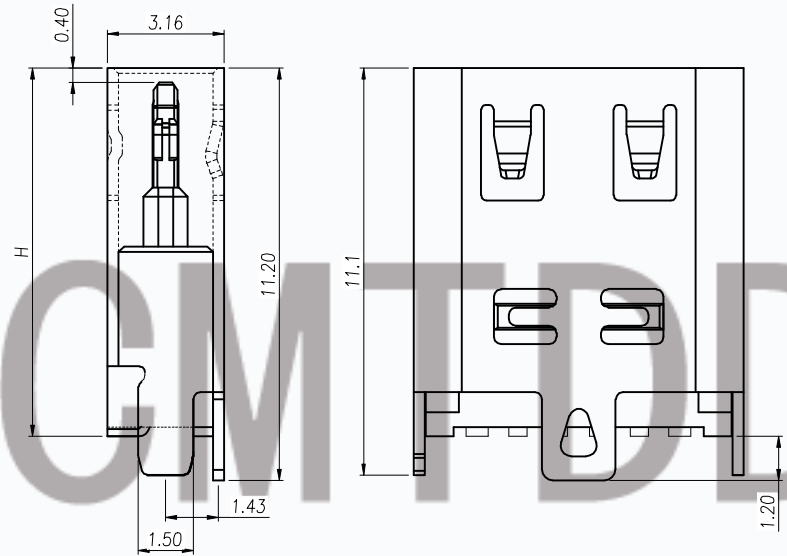
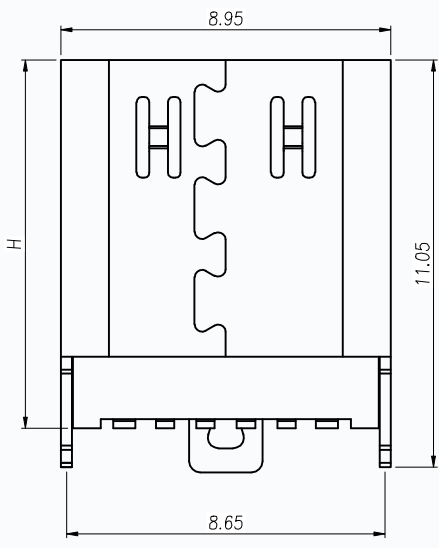
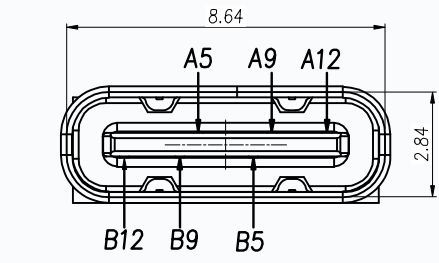

B12	GND
B9	VBUS
B5	CC2
A5	CC1
A9	VBUS
A12	GND
PIN	SIGNAL NAME

H=(MM)
10.0
10.5

UNLESS OTHERWISE SPECIFIED TOLERANCES		CMTDDZ 东莞市田都科技有限公司 DONGGUAN TIANDU TECHNOLOGY CO.,LTD.			
DECIMALS:	ANGLES	TITLE: TYPE-C 6PIN 立贴 H=10.0mm /10.5mm			
X. ±0.20	X' ±2°	Drwn. ERIC	PART NO. T11-06LS02-H		
X.X ±0.10	X.X' ±1°	Checked. JEFF	SCALE: 1:5	UNIT: mm	PROJ.
X.XX ±0.05	X.XX' ±0.5°	Approved. DAVID	SIZE: A4	SHEET: 2 OF 2	REV: A
X.XXX ±0.03					