

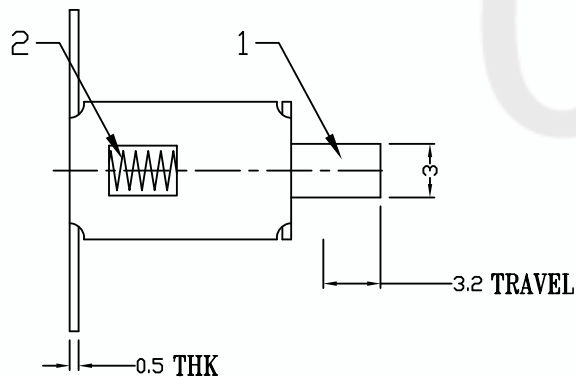

DIMENSIONS

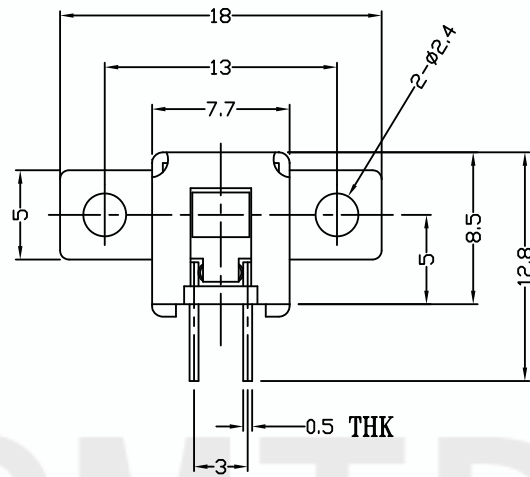

TRAVEL

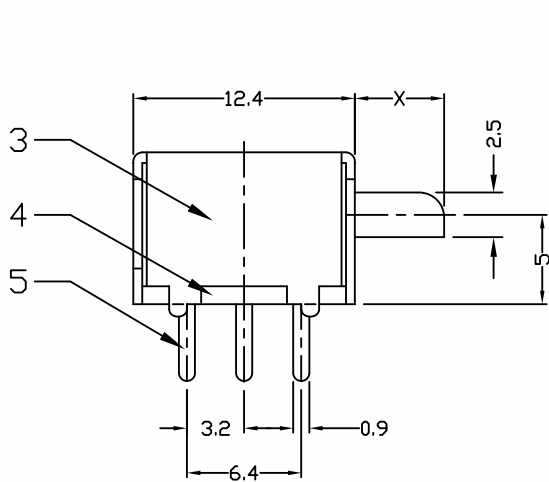
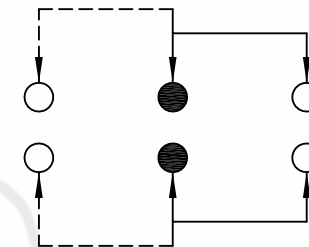
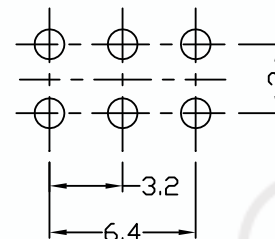

P.C.B LAYOUT

CIRCUIT DIAGRAM

ELECTRO-MECHANICAL CHARACTERISTICS

| | |
|--------------------|---------------|
| Rating | 0.3A 50V DC |
| Circuit | 2P2T |
| Contact Resistance | < 100 mΩ MAX |
| Timing | NON-SHORTING |
| Operating Mode | NON-LOCK |
| Stroke | FULL 3.2mm |
| Operating Force | 100gf ± 30gf |
| Operating Life | 10.000 cycles |

| | | | | |
|-----|--------------|----------------|------|-----------|
| 8 | | | | |
| 7 | | | | |
| 6 | CONTACT CLIP | BRASS | 2 | NI PLATED |
| 5 | TERMINAL | BRASS | 6 | Ag PLATED |
| 4 | BASE | PHENOLIC RESIN | 1 | NATURAL |
| 3 | FRAME | STEEL STRIP | 1 | NI PLATED |
| 2 | SPRING | STEEL WIRE | 1 | NATURAL |
| 1 | KNOB | POM | 1 | BLACK |
| NO. | PARTS | MATERIALS | Q'TY | FINISHING |

| | | | | | | |
|---|--|--|--|--------------------------------|-----------|-----------|
| <p>TOLERANCE UNLESS SPECIFIED</p> <p>WITHIN 1.5mm : ±0.1mm OVER 1.5mm : ±0.2mm</p> | | <p>THESE DRAWINGS AND SPECIFICATIONS ARE THE PROPERTY OF DONGGUAN TIANDU TECHNOLOGY CO., LTD. AND SHALL NOT BE REPRODUCED, COPIED OR USED IN ANY MANNER WITHOUT THE PRIOR WRITTEN CONSENT OF DONGGUAN TIANDU TECHNOLOGY CO., LTD</p> | | DESCRIPTIONS OF REVISION | | APPD. |
| | | | | TITLE : HORIZONTAL PUSH SWITCH | | UNIT : mm |
| MODEL: T5-223004N | | SCALE: 3:1 | | DWN. | ERIC | 2013-6-17 |
| <p>CMTDDZ 东莞市田都科技有限公司 DONGGUAN TIANDU TECHNOLOGY CO., LTD.</p> | | CHK'D | | MAIKO | 2013-6-17 | |
| | | APPD. | | Coco | 2013-6-17 | |