

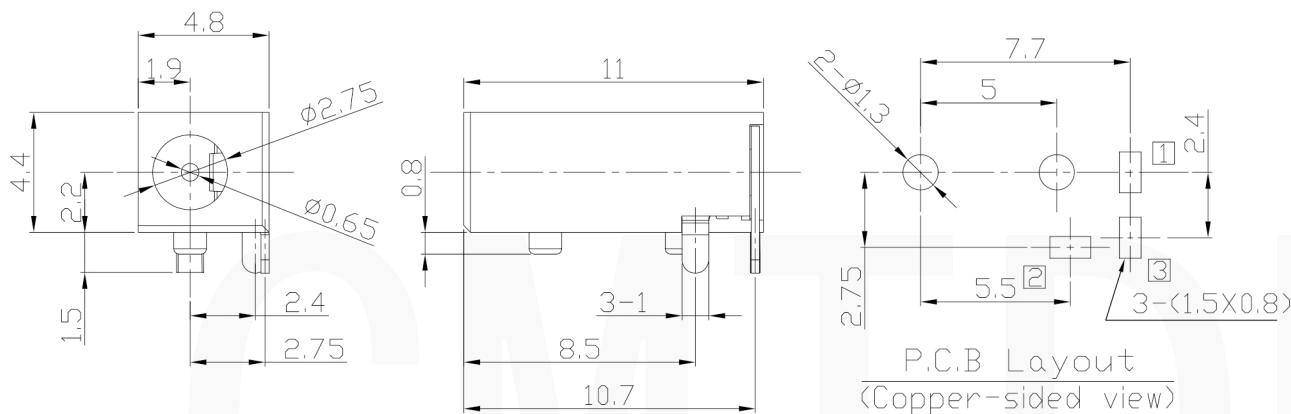

RoHS
Compliant
2002/95/EC

REV.	ECN.	NO.	APPD.

DIMENSIONS



SPECIFICATION:

1. Rating : DC 30V 0.5A;
2. Contact resistance: $\leq 30m\Omega$;
3. Insulation resistance: $\geq 100M\Omega$ (DC500V);
4. Withstand voltage: 500VAC ;
5. Insertion and extraction force: $\leq 30N$;
6. Life test: 5,000 cycles;
7. Operation temperature range: $20^{\circ}C \sim 70^{\circ}C$;
8. Preservative temperature range: $-40^{\circ}C \sim 85^{\circ}C$;

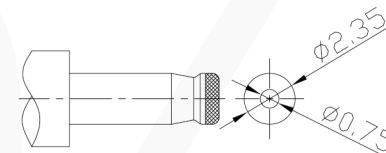

DC MATE PLUG

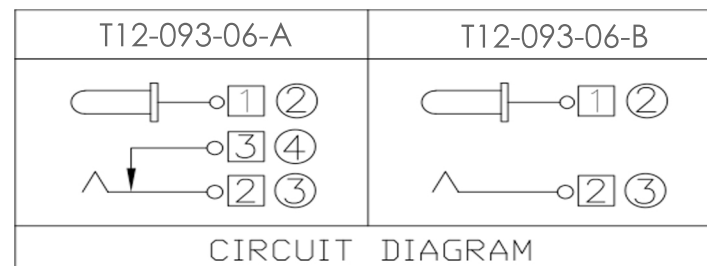
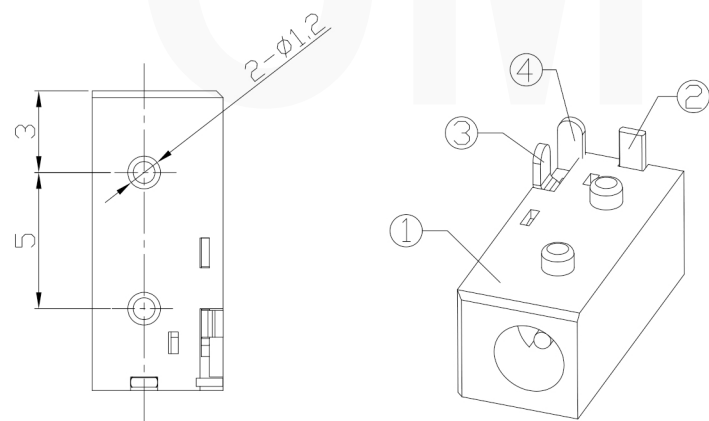

CIRCUIT DIAGRAM

○: ITEM NO. □: TERMINAL NO.

NO.	PARTS	MATERIAL	Q'TY	FINISHING	TOLERANCE UNLESS SPECIFIED WITHIN 1.5mm : $\pm 0.1mm$ OVER 1.5mm : $\pm 0.2mm$	THESE DRAWINGS AND SPECIFICATIONS ARE THE PROPERTY OF DONGGUAN TIANDU ELECTRONICS CO.,LTD. AND SHALL NOT BE REPRODUCED, COPIED OR USED IN ANY MANNER WITHOUT THE PRIOR WRITTEN CONSENT OF DONGGUAN TIANDU ELECTRONICS CO., LTD	DESCRIPTIONS OF REVISION	APPD.	
④	Shunt terminal	Brass t=0.3	1	Ag-Plating					
③	Tip spring	Bronze t=0.3	1	Ag-Plating					
②	Center pin	Bronze	1	Ag-Plating					
①	Housing	PBT UL94V-0	1						
					TITLE : DC JACK	UNIT : mm	DRWG NO.: CMTDDZ-T12-093-0000		
					MODEL: T12-093-XX-A	SCALE: 3:1	DWN.	ERIC	2013-6-17
					CMTDDZ 东莞市田都电子有限公司	CHK'D	MAIKO	2013-6-17	
					DONGGUAN TIANDU ELECTRONICS CO.,LTD.	APPD.	Coco	2013-6-17	