

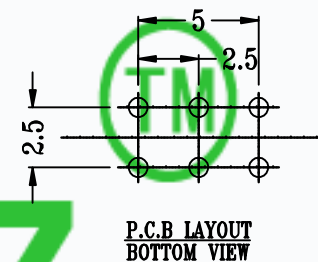

CAD FILE:

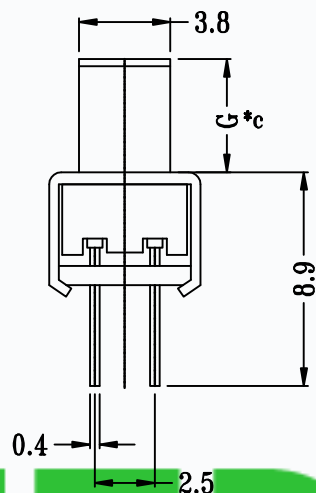

MODEL NO.	KNOB(G/VG)
T2-222502-G	(2~8)mm

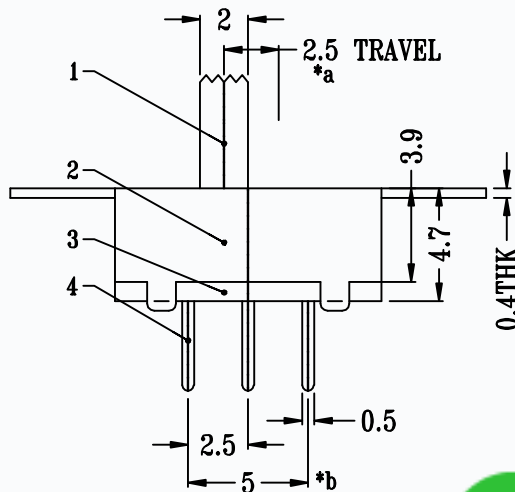

CMTDDZ

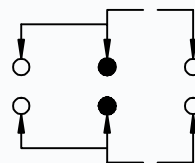
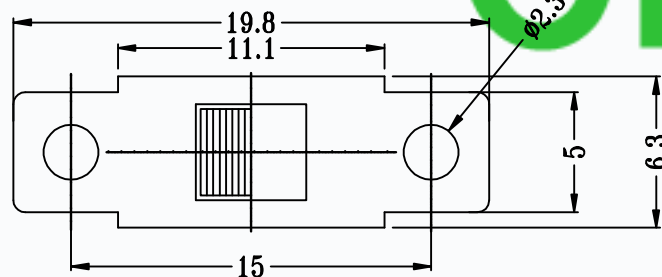

SCHEMATIC (NON-SHORTING)

SPECIFICATIONS

Rating	0.3A 30V DC
CIRCUIT	2P2T
Timing	NON-SHORTING
Travel	2.5mm
Contact Resistance	< 100 mΩ
Operating Force	250gf ± 100gf
Operating Life	10,000 cycles

NO.	PARTS	MATERIALS	Q'TY	FINISH	TOLERANCE UNLESS SPECIFIED	DESCRIPTIONS OF REVISION	APPD.
8					TOLERANCE UNLESS SPECIFIED WITHIN 1.5mm : ±0.1mm OVER 1.5mm : ±0.2mm	THESE DRAWINGS AND SPECIFICATIONS ARE THE PROPERTY OF DONGGUAN TIANDU ELECTRONICS CO.,LTD. AND SHALL NOT BE REPRODUCED, COPIED OR USED IN ANY MANNER WITHOUT THE PRIOR WRITTEN CONSENT OF DONGGUAN TIANDU ELECTRONICS CO., LTD	APPD.
7							
6	SPRING	STEEL WIRE	2	NATURAL			
5	CONTACT CLIP	PBS STRIP	2	Ag PLATED			
4	TERMINAL	BRASS STRIP	6	Ag PLATED OVER Ni PLATED			
3	BASE	PHENOLIC RESIN	1	NATURAL	TITLE : VERTICAL SLIDE SWITCH	UNIT : mm	DRWG NO.: CMTDDZ-T2-222502-00
2	FRAME	STEEL STRIP	1	NI PLATED	MODEL: T2-222502-G	SCALE: 3:1	DWN. ERIC 2013-6-17
1	KNOB	POM	1	BLACK	CMTDDZ 东莞市田都电子有限公司 DONGGUAN TIANDU ELECTRONICS CO.,LTD.	CHK'D MAIKO	2013-6-17
						APPD. Coco	2013-6-17