

MODEL NO.	KNOB(G)
T4-124707-X	(2~10)mm

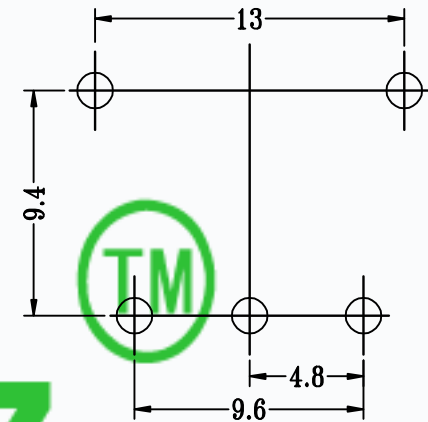

P.C.B LAYOUT

CMTDDZ

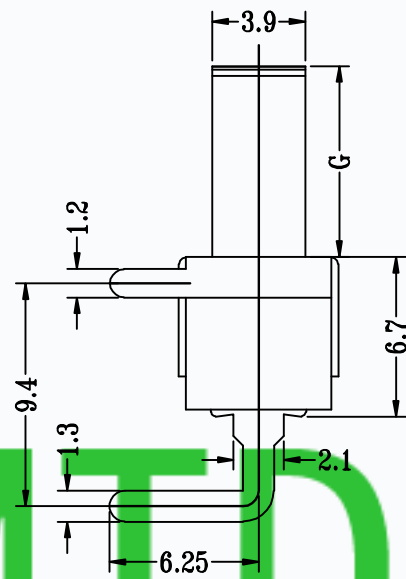
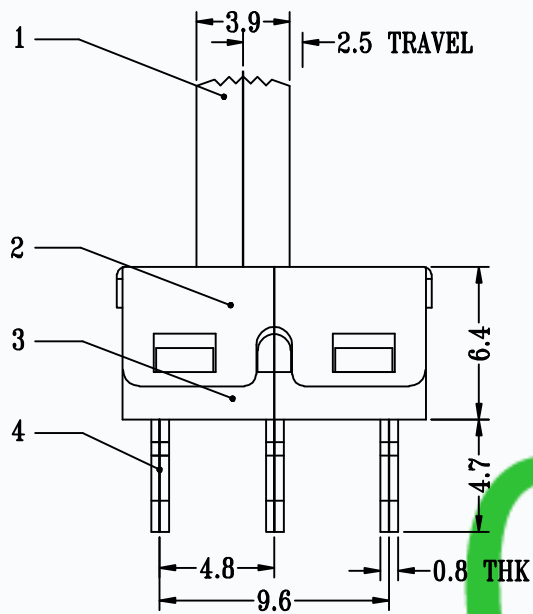
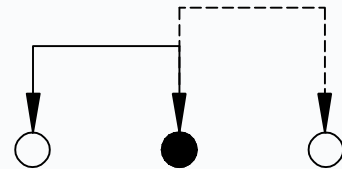
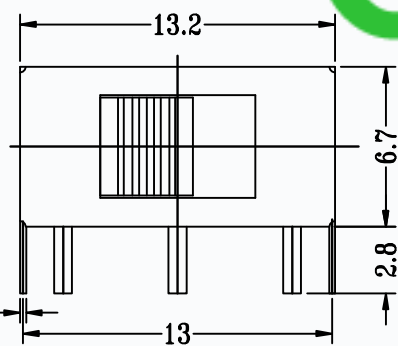

SCHEMATIC(NON-SHORTING)

SPECIFICATIONS	
Rating	AC125V 1.5A
CIRCUIT	1P2T
Insulation Resistance	> 100 MΩ
Travel	2.5mm
Contact Resistance	< 100 mΩ
Operating Force	300gf ± 100gf
Operating Life	10,000 cycles

NO.	PARTS	MATERIALS	Q'TY	FINISH
8				
7	STEEL BALL	STEEL	1	NATURAL
6	SPRING	STEEL WIRE	1	NATURAL
5	CONTACT CLIP	BRASS STRIP	1	Ag PLATED
4	TERMINAL	BRASS STRIP	3	Ag PLATED
3	CASE	PA66	1	BLACK
2	COVER	SUS	1	NATURAL
1	KNOB	PA66	1	BLACK

TOLERANCE UNLESS SPECIFIED	THESE DRAWINGS AND SPECIFICATIONS ARE THE PROPERTY OF DONGGUAN TIANDU ELECTRONICS CO.,LTD. AND SHALL NOT BE REPRODUCED, COPIED OR USED IN ANY MANNER WITHOUT THE PRIOR WRITTEN CONSENT OF DONGGUAN TIANDU ELECTRONICS CO., LTD	DESCRIPTIONS OF REVISION	APPD.
WITHIN 1.5mm : ±0.1mm			
OVER 1.5mm : ±0.2mm			
TITLE : VERTICAL SLIDE SWITCH		UNIT : mm	DRWG NO.: CMTDDZ-T4-124707-00
MODEL: T4-124707-G		SCALE: 3:1	DWN. ERIC 2013-6-17
CMTDDZ 东莞市田都电子有限公司 DONGGUAN TIANDU ELECTRONICS CO.,LTD.		CHK'D	MAIKO 2013-6-17
		APPD.	Coco 2013-6-17