

CAD FILE:

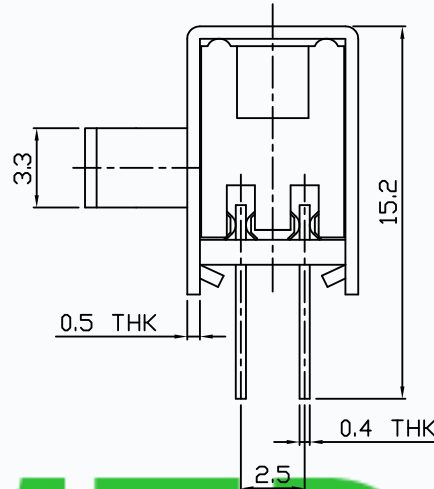

MODEL NO.	KNOB(G/VG)
T3-232001-G	(2~15)mm

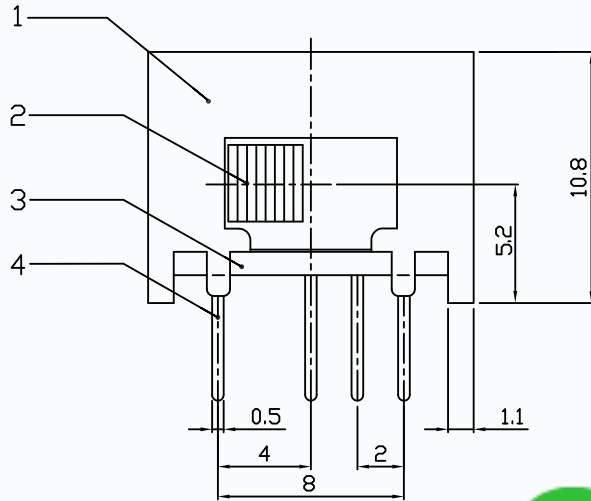
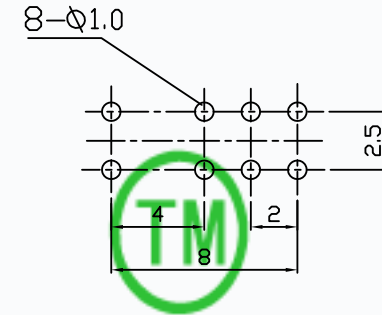

P.C.B. LAYOUT

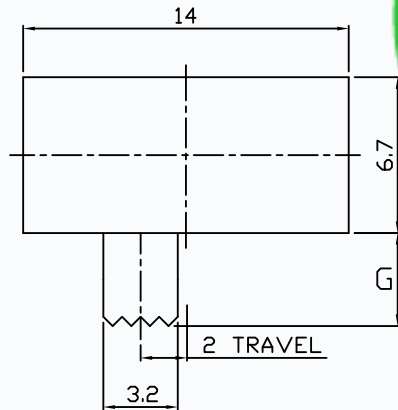

**CMTDDZ**

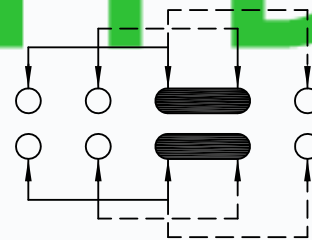

SCHMATIC (NON-SHORTING)

SPECIFICATIONS

Rating	0.3A 50V DC
CIRCUIT	2P3T
Timing	NON-SHORTING
Travel	2.0mm
Contact Resistance	< 100 mΩ
Operating Force	250gf ± 100gf
Operating Life	10,000 cycles

NO.	PARTS	MATERIALS	Q'TY	FINISH
8				
7	STEEL BALL	STEEL	1	NATURAL
6	SPRING	STEEL WIRE	1	NATURAL
5	CONTACT CLIP	PBS STRIP	2	Ag PLATED
4	TERMINAL	BRASS STRIP	8	Ag PLATED
3	BASE	PHENOLIC RESIN	1	NATURAL
2	KNOB	POM	1	BLACK
1	FRAME	STEEL STRIP	1	NI PLATED

TOLERANCE UNLESS SPECIFIED	WITHIN 1.5mm : ±0.1mm	OVER 1.5mm : ±0.2mm	THESE DRAWINGS AND SPECIFICATIONS ARE THE PROPERTY OF DONGGUAN TIANDU ELECTRONICS CO.,LTD. AND SHALL NOT BE REPRODUCED, COPIED OR USED IN ANY MANNER WITHOUT THE PRIOR WRITTEN CONSENT OF DONGGUAN TIANDU ELECTRONICS CO., LTD		
TITLE : HORIZONTAL SLIDE SWITCH			UNIT : mm	DRWG NO.: CMTDDZ-T3-232001-00	
MODEL: T3-232001-G			SCALE: 3:1	DWN.	ERIC 2013-6-17
<b>CMTDDZ</b> 东莞市田都电子有限公司				CHK'D	MAIKO 2013-6-17
DONGGUAN TIANDU ELECTRONICS CO.,LTD.				APPD.	Coco 2013-6-17

DESCRIPTIONS OF REVISION			APPD.